

# ACCUSEAL® STEAM SERVICE CHOKES



## GENERAL DESCRIPTION:

The Accuseal® Steam Service Choke valve is a multiple orifice disc style suitable for many applications. The simple design of the disc style allows for easy sizing, trim changes appropriate for various flow requirements, as well as field repairs.

## FEATURES AND BENEFITS

- 1/4 turn
- Live Loaded Packing Arrangement for reliable stem sealing
- End Connections-1", 1 1/2", 2" SW (standard); RF, RTJ (available)
- ASME Class 900/1500
- **Disc Material:** Tungsten Carbide & 17-4 PH
- **Body Materials:** Carbon Steel and 316 SS
- **Wear Sleeve:** Tungsten Carbide

### Orifice Sizes Available

Sizes	Rated Cv
3/16"	1.6
1/4"	2.9
3/8"	6.6
1/2"	11.7
5/8"	18.4
3/4"	26.4

---

## ARRAY HOLDINGS, INC., D.B.A. ARRAY PRODUCTS

16680 Air Center Blvd., Suite 100, Houston, Texas 77032  
Phone: 281.821.8258 • Fax: 281.821.8259 • [www.array.com](http://www.array.com)



ARRAY

# ACCUSEAL® STEAM SERVICE CHOKES

## PARTS LIST

NO.	DESCRIPTION	MATERIALS
1.	Body	A105
2.	Belleville Spring	17-4 PH H1150 + 1150
3.	Stem	17-4 PH H1150 + 1150
4.	Stem Bushing	410 SS - QPQ
5.	Guide Bearing	Naval Brass
6.	Packing Follower	410 SS - QPQ
7.	Gland Flange	17-4 PH
8.	Bonnet	A105
9.	Wear Sleeve	17-4 PH H1150 + 1150
10.	Body Gasket	304 SS - Grafoil Filled
11.	Outer Cage	17-4 PH H1150 + 1150
12.	Drive Cage	17-4 PH H1150 + 1150
13.	Packing Bushing	410 SS - QPQ
14.	Nut-Packing Gland	A194 Gr. 8M
15.	Stud-Packing Gland	A193 B8M CL.1
17.	Ferry Cap Screw	A193 B7
18.	Belleville Spring - Live Loaded	17-7 PH
19.	Washer	304 SS
20.	Packing Ring	Grafoil
21.	Anti-Extrusion Ring	Inconel 718 / Grafoil
22.	Seal Ring	Grafoil
23.	Spring	A-286
24.	Retaining Ring	302 SS
25.	Choke Disk	WC
26.	Bracket	Stainless Steel
27.	Dowel Pin	Alloy Steel
28.	Dowel Pin	Alloy Steel

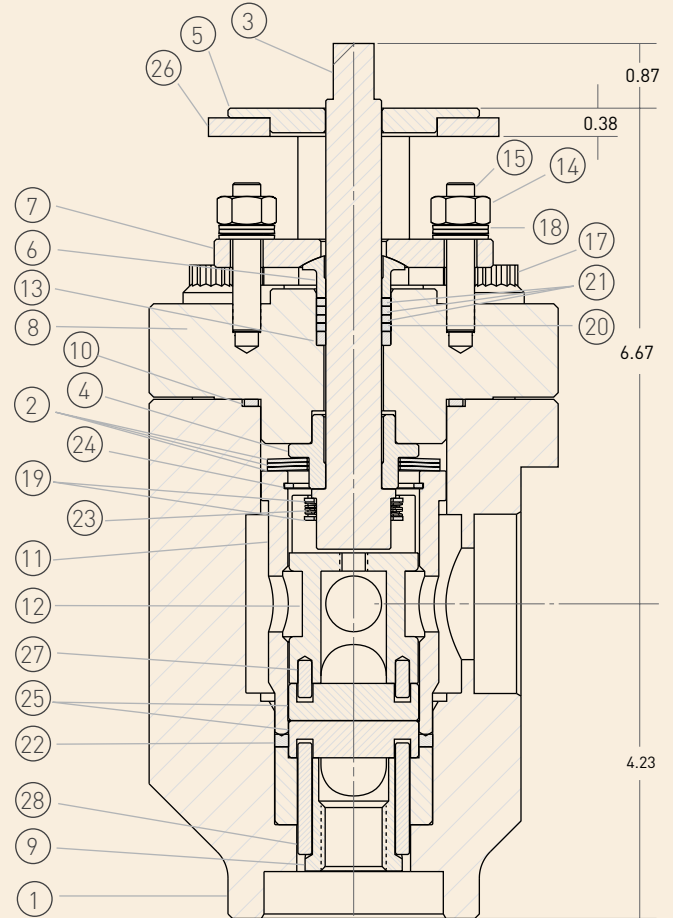

### LIMITED PRODUCT WARRANTY (SPECIAL WARRANTIES AVAILABLE)

The following warranty is exclusive and in lieu of all other warranties. Whether express, implied or statutory, including, but not by way of limitation, any warranty of merchantability or fitness for any particular purpose.

Array Products warrants to each original buyer of products manufactured by Array that such products are free from defects in material and workmanship under normal use and service for a period of one (1) year from the date of shipment provided that no warranty is made with respect to: Any product which has been repaired or altered in such a way in ARRAY's judgment, as to affect the product adversely; Any product which has, in ARRAY's judgment, been subject to negligence, accident or improper storage; Any product which has not been operated or maintained in accordance with normal practice and in conformity with recommendations and public specification of Array.

ARRAY's obligation under this Warranty is limited to use reasonable efforts to repair, replace or, at it's option, refunding the purchase price. The cost of labor for installing a repair or replacement product shall be borne by Purchaser. Replacement parts provided under the terms of this Warranty are warranted for the remainder of the warranty period of the products upon which they are installed to the same extent as if such parts were original components thereof. Warranty services provided there under do not assume any liability for damages caused by any delays involving warranty service. For complete specification information, prices and name, address and telephone number of the ARRAY representative nearest you, call or write to us at the address below.